

KROM HISABATI-12

/ Carrete estándar: 10 metros.
 / Totalidad de puntos de soldadura estañados.
 / Posibilidad de corte a medida.
 / Regulable.
 / Vista superior.

/ Standard reel: 10 meters.
 / Welding points totally tinned.
 / Possibility of custom cut.
 / Dimmable.
 /Top View.

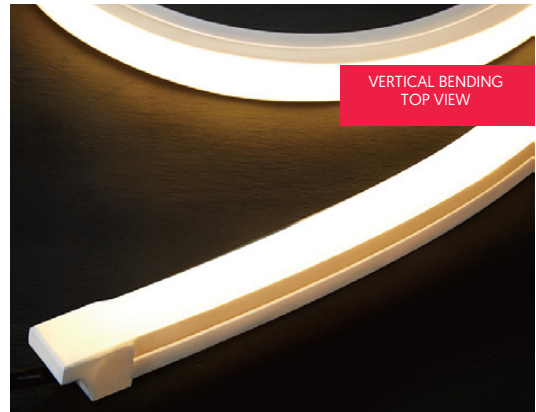

UNIQUE BIN	CRI > 97	TOP VIEW	LIGHT UNIFORM	10 W/m	24 V DC	620lm/m
------------	----------	----------	---------------	--------	---------	---------

MEICON®

DIMENSIONES/ÓPTICA DIMENSIONS/OPTICS

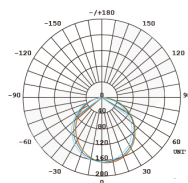

ESPECIFICACIONES SPECIFICATIONS

V _{nom} DC	24 V
Potencia Power	10W/m
R9	90
Índice de reproducción cromática CRI	>97
Temperatura de color LED LED Color Temperature	3000K
Flujo luminoso Luminous flux	620lm/m
Eficiencia Efficiency Lm/W	62lm/W
Tamaño elemento Min. element size	50mm
Ángulo Angle	120°
Protección IP IP Protection	67



CARACTERÍSTICAS FEATURES

/ Unidad de corte marcada en el PCB y plano (50mm).
 / Disponible para interior/exterio.
 / Alimentación en 24 V DC - según normativa de baja tensión.
 / Aplicaciones: Iluminación general, de acento y decoración; arquitectura, retail, equipamiento y horeca.
 / Max. diámetro de flexión >60 mm.
 / Alimentación por un lado para equipos de máximo 5 metros.
 / Alimentación por ambos lados para equipos de máximo 10 metros.

/ Cutting unit marked on PCB and drawing (50mm).
 / Available for indoor/outdoor use.
 / Power supply at 24 V DC - according to low voltage regulations.
 / Applications: General illumination, accent and decoration; architecture, retail, equipment and horeca.
 / Max. Bending diameter >60 mm.
 / Feeding on one side for equipment up to 5 meters.
 / Feeding on both sides for equipment up to 10 meters.

Calificación máxima absoluta en T_a= +00°C. Los rendimientos luminicos pueden verse incrementados hasta en un 30% en condiciones específicas de laboratorio.
 Absolute maximum rating at T_a= +00°C. Luminous yields can be increased by up to 30% under specific laboratory conditions.

*Pruebas de tolerancia aceptable CRI: -1. CRI testing acceptable tolerance: -1.

*Las imágenes son ilustrativas. Los productos finales están sujetos a cambios sin aviso previo. *Images for reference only. Subject to changes without prior notice.

*Disponibles otras temperaturas de color bajo pedido. *Other colour temperatures available under request.

CERTIFICACIONES CERTIFICATIONS



DIBUJOS DE PERFIL PROFILE DRAWINGS

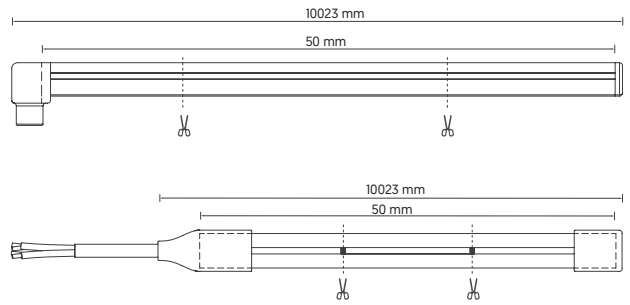
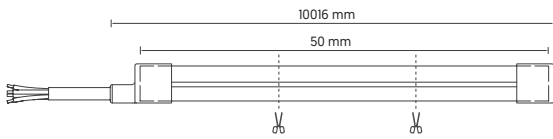

CURVA BEND

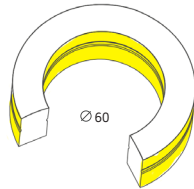
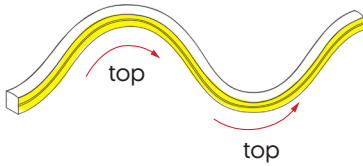

TECNOLOGÍA IP IP PROCESS TECHNOLOGY

SILICONA GLUE PROCESS (IP67)

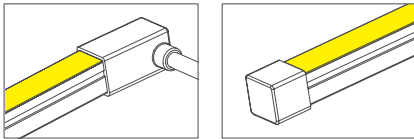

DIRECCIÓN DE SALIDA OUTLET DIRECTION

Recto / Izquierda / Derecha / Abajo
Straight / Left / Right / Bottom

MOLDEADO MOLDING PRESSED (IP67)

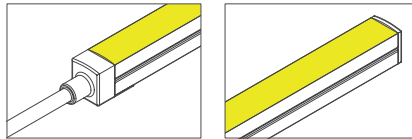

DIRECCIÓN DE SALIDA OUTLET DIRECTION

Recto / Izquierda / Derecha / Abajo
Straight / Left / Right / Bottom

MOLDEADO MOLDING PRESSED (IP68)

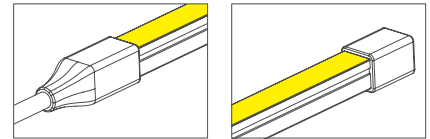

DIRECCIÓN DE SALIDA OUTLET DIRECTION

Recto
Straight

ACCESORIOS ACCESORIES



TAPA CABLE
CABLE CAP



SILICONA
SILICONE



CARRIL DE ALUMINIO
ALUMINUM RAIL



TAPA CABLE 90°
CABLE CAP 90°



TAPA CIEGA
END CAP



TORNILLOS
SCREWS



TAPA CIEGA
END CAP



TAPA CABLE
CABLE CAP



CARRIL DE ALUMINIO
ALUMINUM RAIL



TAPA CABLE
CABLE CAP



TAPA CIEGA
END CAP



3,5cm CLIP ALUMINIO
3,5cm ALUMINUM CLIP



SNAKE



CLIP
SILICONE